

# User guide

Care and Maintenance  
Ventilation and indoor climate  
Operation and adjustment

# Congratulations on your new Rationel windows

You have chosen a high quality product that has been produced in accordance with exceptional Danish construction principles and manufactured in Rationel's modern factories. Regular care and maintenance of your windows and doors is important in order to ensure the longevity of the product. Professional installation of your windows and doors will ensure optimum functionality including ensuring they are clean and free from all builders dirt and spoil from the construction process. The installer will then be able to fully adjust all units and ensure they are ready for many years of use.

## Share your windows/doors with us

We would love to see your windows and doors when they have been installed. If you have any photos of your project – both before and after – by all means share them with us on Instagram, or send us an email.



Instagram  
[@rationelwindows](https://www.instagram.com/rationelwindows)



Mail  
[enquiries@rationel.ie](mailto:enquiries@rationel.ie)

We hope you enjoy your new windows and doors.

Kind regards,  
Rationel

# Content

4	Care and maintenance
5	Ventilation and indoor climate
6	Operation and adjustment
12	Accessories
13	Record of Rational products
14	Warranty
15	Glossary

# Care and maintenance

## Windows and doors

There are a few general guidelines for the care and use of all Rationel products that you have to follow in order to maintain your warranty. However, please be aware that the amount of care and maintenance for the outside of your window/door is dependent on whether you have chosen wood (Rationel AURA/FORMA) or a wood/aluminium combination (Rationel AURAPLUS/FORMAPLUS).

### External care of timber

Timber windows and doors require maintenance, but not much as long as the work is done in a timely fashion. A visual inspection should be carried out once a year, to check the external surfaces are free from any splits or cracks in the paintwork or timber. This is particularly applicable to south and west-facing façades, bay windows and suchlike, where the UV rays of the sun are heavier on woodwork of all kinds. Buildings without overhanging eaves are also more vulnerable. If the paint cracks, this invites moisture to enter the wood and the wood starts to break down.

When carrying out remedial works to your windows and doors, the humidity of the wood should be 12% +/- 2%, with an air temperature of around 10-20 degrees. The humidity of the wood can be measured using a hygrometer, which you can buy inexpensively from most paint dealers or builders merchants. Do not start working until the overnight dew has disappeared, and stop working early enough to allow the paint to “hand-dry” before dewfall.

We recommend you use a water based primer and topcoat with anti-fungal properties to prevent algae and mould. We use water-based paints, gloss 20, at the factory.

Otherwise, frames and sashes should be washed down at least twice a year. This removes dirt and other contamination that will break down the surface in the long term. Get into the habit of washing the frames and sashes when you clean the glass. Use water with a mild, pH-neutral detergent added.

### External care of aluminium

If you have chosen windows and doors made of timber with external aluminium cladding, the amount of maintenance you will have to do is very limited. You should wash down the external aluminium a couple of times a year, but ideally you should get into the habit of washing the frames and sashes when you clean the glass.

Minor scratches in aluminium can be removed using a polishing agent if your window or door has been physically damaged, but do not do this on matt (gloss 30) and granite surfaces. Deep scratches that go all the way through the surface and down to the bare aluminium are automatically subject to oxidation that closes the “wound” and prevents further oxidation. Deep scratches can be repaired and painted if preferred, and we would recommend a qualified painter carry out such works.

### Panelled door care

The outside of the door should be painted with diffusion-open paint every three years, or as required.

### Internal care of timber

The internal part of the window does not really require much care to guarantee its service life. However, in most rooms it will be necessary to remove dust and dirt from the frame and sash. How often you need to do this depends on how much dust and dirt there is in your room, but a recommendation of every 6 months is advisable. In rooms such as kitchens where a build-up of grease and smoke is likely, cleaning is recommended more often. Your window/door should be cleaned using a cloth and mild, pH-neutral, soapy water.

### Care of rubber gaskets

Rubber gaskets require little maintenance, but should be cleaned using a cloth and soapy water, and a little silicone care product to keep the strips soft. If you want to re-paint your windows at any time, you must make sure you do not get paint or wood preservative on the rubber strips. If you do, they will lose the flexibility needed to seal the window or door tightly.

### Cleaning the glass

How often you clean your windows is all down to personal preference, but as a minimum the glass should be cleaned approx. 4 times per annum. Use a soft brush and a squeegee – and use mild, soapy water, possibly with a rinse aid added to prevent the formation of limescale. Stickers on windows can be removed by softening them in water. Residues from stickers or other labels can be removed using ceramic hob cleaner, but be gentle.

### Lubricating hardware

The fittings do not require much maintenance. However, it is sensible to apply a couple of drops of acid-free oil to moving fittings a couple of times a year so that they continue to move smoothly. Use acid-free oil such as sewing machine oil. You should use Interflon Finelube (Teflon spray) for side swing/side guided windows.

Windows situated in exposed areas, particularly coastal locations (within 5 miles), should be oiled more frequently.

Replacement of vulnerable fittings may be necessary after a number of years, in extreme cases. You must also ensure that you keep any gliding tracks on windows clean and free of dust and dirt. This will ensure your windows are always fully functional.

### Adjustment

Be aware that daily use and wear and tear over time will mean the fittings in your windows and doors will need to be adjusted. This is why opening elements should be inspected once a year and adjusted as necessary to ensure that the frame is positioned correctly in the casing and that it closes tightly. Adjustments are the responsibility of your installer to complete initially, and your maintenance provider to maintain, and are not covered by our product warranty. Adjustments can ensure that the components of the unit align and sit within the frame correctly (thus ensuring proper operation, even sightlines, sealing function and unnecessary resistance on the ironmongery, which can lead to failures) – they must be carried out once the units are in situ and may be required in the future once the units have settled into their positions. Rationel reserve the right to apply a charge for any matters not attributed to a product defect.

# Ventilation and indoor climate

## Ventilation

All new windows are airtight. This often means that you need to change your habits when getting new windows installed, especially if your previous ones were old and draughty. These may have made sure that your home was naturally ventilated, even when you did not want it.

You will need to make sure that your home is ventilated properly. It is a myth that it costs a lot, in terms of both energy and money, to ventilate our homes thoroughly. You just need to make sure you do it right.

Leave a window or a door open if you can, so that it causes a draught. This will replace the hot, moist indoor air with cool, dry air from outside and takes less than 10 minutes. The heavy items in the room, such as furniture, floors, walls, etc., will not cool down in that short time – and the amount of energy you lose will be so small that you will barely notice it.

Ventilation is especially important in new buildings. The moisture left behind in walls and floors during construction can remain there for up to 2 years.

If you ventilate your home thoroughly a couple of times a day – e.g. your bedroom and bathroom in the morning, and the kitchen, family room and living room in the evening – you will help to guarantee a pleasant and healthy indoor climate for you and your family.

## Condensation on windows

Condensation is often a sign of a lack of ventilation. However, that is not always the case. It depends entirely on whether the condensation appears on the inside, outside, or between the panes of glass.

### Condensation on the outside of the window – a positive problem

Condensation on the outside of the window is a positive problem as long as it only appears on the outside of the window. This proves that the window is energy-efficient and works as intended.

With some types of weather, for instance, frosty nights where there is a great deal of heat radiation from the ground into the air, there may be times in the early hours of the morning when the outer surface of the energy window is colder than the outdoor air. This causes mist to form in the middle of the outside of the window. This mist disappears when the outside air temperature rises throughout the day.

This misting is caused by the energy window, where the innermost pane of glass is provided with an invisible coating that reflects the heat back to the premises. At the same time, the space between the two panes of glass in the window is filled with argon, an inert gas, which also helps to prevent the heat from inside reaching the outermost pane of glass and heating it up. This is why it is possible for the outside of the energy window to be colder than the outdoor air. Mist on the outside cannot occur with traditional, old-fashioned double glazing, where a small amount of heat always escapes through the window and heats the outermost pane of glass.

### Condensation on the inside of the window – ventilate!

If condensation appears on the inside of the glass pane, it is a sign that the relative humidity inside your home is too high. The humidity should be brought down if you want to avoid rot and moisture damage, as well as a poor indoor climate.

### Condensation between the two panes of glass – the window is punctured!

If you encounter condensation between the two panes of glass, this is a sign that the sealed unit is punctured and should be replaced.

## Finger-jointed timber

Rational uses finger-jointed timber to produce its doors and windows. This means that all significant knots on visible surfaces have been removed from the timber to minimise resin extract. Timber is a natural living material, therefore there is a chance that further resin extract may occur after manufacture.

For removal of resin extract we recommend that either:

- for freshly bleeding knots, the resin is cleaned away with white spirit if it appears above the paint surface. This cleans the released resin and bleaches the knot. The area should be cleaned over with water, lightly sanded and re-painted.

or

- The resin is rubbed down later if it is allowed to harden. Preparation and re-painting works as described above. This is normally carried out at the first maintenance cycle when the knots will probably have ceased to exude. According to the British Woodworking Federation this is the best solution.

Rationel windows and doors

# Operation and adjustment

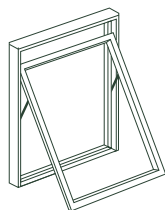

## Top guided window

Rationel AURA & AURAPLUS  
Rationel FORMA & FORMAPLUS

### Operation

The window is operated with the handle, which activates the locking mechanism, making it possible to:

- 1) open
- 2) close
- 3) set the window sash to a ventilation position\*

For ventilation, you can use the night vent position by turning the handle to engage the closing mechanism in the outer hole of the receiver plate located at the bottom of the window sash. This locks the sash open creating an air gap that allows a limited amount of fresh air to enter through the window.

### Adjustment

Det topstyrede vindue leveres med en justerbar friktionsbremse. If you need to adjust the position of the sash within the frame, this is done by turning the adjustment screws found on either side of the frame (**illustration A**). A 5mm Allen key is used for this.

The friction is adjusted by tightening or loosening the screw in the casing using a 4 mm Allen key (**illustration B**).

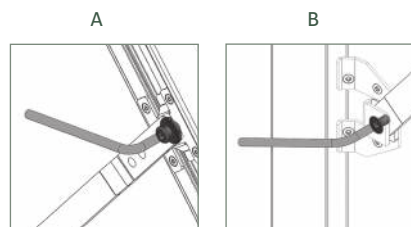

\* Only on windows larger than 530mm wide.

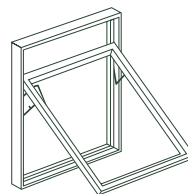

## Top swing window

Rationel AURA & AURAPLUS  
Rationel FORMA & FORMAPLUS

### Operation

The window is operated with the handle, which activates the locking mechanism, making it possible to:

- 1) open
- 2) close
- 3) set the window sash to a ventilation position\*
- 4) turn the window sash to a cleaning position

You can place the window in the ventilation position by turning the handle to the horizontal position so that the closing mechanism engages in the outermost of the two holes in the receiver plate located in the side casings. This holds the sash in position while also creating an air gap that allows a limited amount of fresh air to enter through the window.

The top swing window can turn around so that the outside of the window can be cleaned from inside.

This window comes with a built-in restrictor for safety reasons, preventing the window opening more than about 5 cm. To release the restrictor (**illustration A**), pull the sash about 0,5 cm back, then press on the rear part of the restrictor and push the sash out.

The window also has a cleaning safety catch (**illustration B**) which engages automatically when the sash is turned all the way round. To close the window, you will need to release the restrictor by opening the window even further bringing it towards you to release the catch – the window can then be closed.

Never start cleaning the window until you have checked that the cleaning safety catch is locked in position!

### Adjustment

If you need to adjust the sash within the frame, this is done by turning the adjustment rivets in the middle of the jambs on either side of the frame (**illustration C**).

Use a 22 mm spanner for this. To gain enough access, the adjacent plastic piece should be removed during adjustment (**illustration D**).

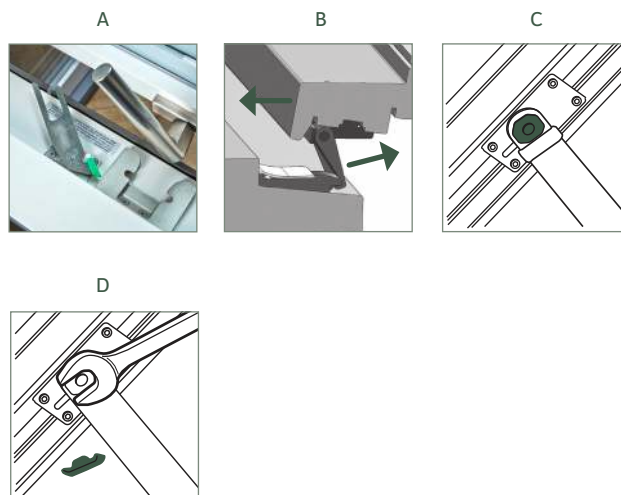

\* Only on windows larger than 530mm wide.

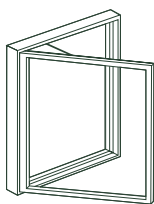

## Side hung window

Rationel AURA & AURAPLUS  
Rationel FORMA & FORMAPLUS

### Operation

The window is operated with the handle, which activates the locking mechanism, making it possible to:

- 1) open
- 2) close
- 3) set the window sash to a ventilation position\*

The side-hung window is supplied with a handle operated brake\*\* that can hold the window frame in any open position, up to 85 degrees.

The handle-operated brake is operated by turning the handle to a vertical position when you have opened the window to the point where you want to hold it. In very windy conditions, you must close the window or ensure that the window does not over extend and cause damage.

You can place the sash in the ventilation position by turning the handle to the vertical position\* so that the closing mechanism engages the outermost of the two holes in the receiver plate located in the side casings. This holds the sash in position while also creating an air gap that allows a limited amount of fresh air to enter through the window.

Double casement windows can be fitted with a false mullion to comply with local fire regulations. The handle on the secondary leaf has a built-in child safety device.

### Adjustment

If there is any need to adjust the height of the sash in the frame, this is done by turning the adjustment screw on the underside of the bottom hinge using a 5 mm Allen key (**illustration A**). Two hinges will have to be adjusted if the sash is more than 1200 mm high. Lateral adjustment takes place by turning the two screws in the hinges using a 5 mm Allen key (**illustration B**). It is important to adjust the screws on the top of the frame equally – the fittings must not be distorted.

The handle-operated brake can be tightened using a 2 mm Allen key (**illustration C**).

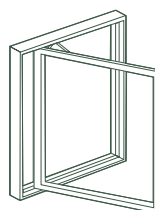
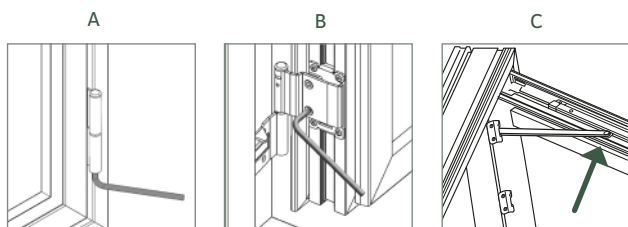

## Side swing/side guided window

Rationel AURA & AURAPLUS  
Rationel FORMA & FORMAPLUS

### Operation

The window is operated with the handle, which activates the locking mechanism, making it possible to:

- 1) open
- 2) close
- 3) set the window sash to a ventilation position\*

A side-guided window can open just under 90° in a way that creates an opening in the "hinge side", allowing the outside of the window to be cleaned from the inside.

A side swing window can be opened and closed so that the outside can be cleaned from indoors. The opening angle is dependent on the frame width. When the sash is opened, an opening restrictor is released (**illustration A**) which must be deactivated if you want to turn the frame to the cleaning position.

The opening restrictor (**illustration A**) also works as a cleaning safety catch when the frame is fully turned.

You can also choose to use the night ventilation position\* by turning the handle to the vertical position when the closing mechanism engages the outermost of the two holes in the receiver plate located in the side casings. This holds the sash in position while also creating an air gap that allows a limited amount of fresh air to enter through the window.

### Adjustment

If you need to adjust the height of the sash in the frame, this is done by first loosening the screw on the bottom hinge using a 2.5 mm Allen key (**illustration B**).

Then adjust the frame up or down by turning the screw on the underside of the frame using a 4 mm Allen key (**illustration C**) and finish by refastening the first screw (the key is mounted on the back of the frame). Lateral adjustment takes place by turning the adjusting screws at the top and bottom of the frame (**illustration D**).

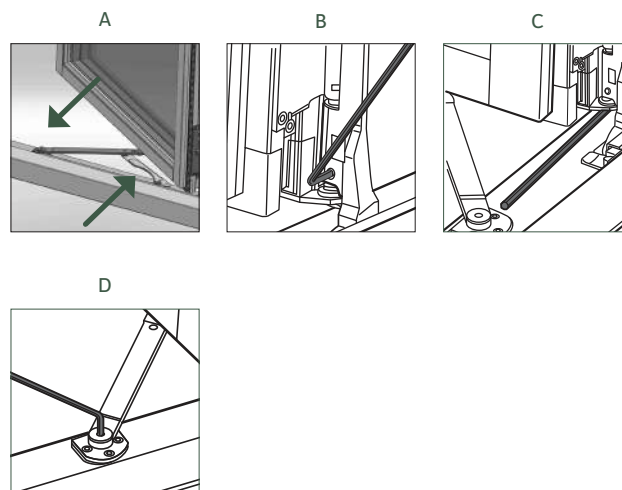

\* Only on windows larger than 530mm wide.

\*\* Only on windows larger than 424mm and 530 high.

\* Only on windows larger than 530mm wide.





## Entrance/Panelled door

Rationel AURA & AURAPLUS  
Rationel FORMA & FORMAPLUS

### Operation

The espagnolette lock on a Rationel Entrance door has three locking points. When locking the door, all 3 of the door lock points will be activated, and this is done by lifting the door handle upwards. This must be done before the door can be locked by turning the key.

Entrance doors may have two leaves. In this case, you open the secondary door by releasing the flush bolt located in the groove on the side jamb (**illustration A**).

### Adjustment

Rationel doors can be adjusted without removing the door leaf. The height between the door frame and sill can be adjusted by 5 mm (+/- 2.5 mm) using the thread in the supporting pins at the bottom of the hinges (**illustration B**). Use a 6 mm Allen key. If lateral adjustment is required, you first have to loosen the large screws (**illustration C**) in the hinges on the frame (use a torx 20 screwdriver) and then adjust using the two small hexagonal screws on the jamb using a 3 mm Allen key. Finally tighten the 4 screws in the frame again.

The pressure on the sealing strip can be regulated by adjusting the striking plate. Remove the two guide pins on the top plate using pincers. Then move the top plate backwards or forwards before securing the plate in position (**illustration D**).

In the case of a double entrance door, the pressure of the frame on the sealing strip can also be adjusted by undoing the top striking plates in the bottom and top of the casings (**illustration E**). You then rotate the underlying striking plate clockwise or anticlockwise through 90°, depending on whether you want to increase or reduce the pressure. Finally, the plates should be secured in position.

The frame lifter (**illustration F**), which supports the door when it is closed, must be height-adjusted when the door is installed or after adjustment. Loosen the two screws in the espagnolette – you will then see a small wheel at the bottom of the door frame. This wheel is adjusted up or down by loosening or tightening the two screws. The wheel must abut against the bottom casing when adjustment is complete.



## Terrace door

Rationel AURA & AURAPLUS  
Rationel FORMA & FORMAPLUS

### Operation

The terrace door is opened using a handle that activates a closing mechanism with three locking points. This locking system comes equipped with a handle-operated brake that can hold the door in any open position up to 85 degrees. The handle-operated brake is operated by turning the handle to a vertical position when you have opened the door to the point where you want to hold it. In very windy conditions, you must close the door or ensure that the door does not over extend and cause damage.

Terrace doors may have two leaves. In this case, you open the secondary door without a handle by releasing the flush bolt located in the groove on the side jamb (**illustration A**). Please note the secondary leaf does not have a handle-operated brake.

### Adjustment

Rationel doors can be adjusted without removing the door leaf. The height between the door frame and sill can be adjusted by 5 mm (+/- 2.5 mm) using the thread in the supporting pins at the bottom of the hinges (**illustration B**). Use a 6 mm Allen key. If lateral adjustment is required, you first have to loosen the large screws (**illustration C**) in the hinges on the frame (use a torx 20 screwdriver) and then adjust using the two small hexagonal screws on one of the casing hinges. Use a 3 mm Allen key.

The pressure on the sealing strip can be regulated by adjusting the striking plate. Remove the two guide pins on the top plate using pincers. Then move the top plate backwards or forwards before securing the plate in position (**illustration D**).

In the case of double patio doors, the pressure of the frame on the sealing strip can also be adjusted by undoing the striking plates in the bottom and top casings (**illustration E**). You then rotate the underlying striking plate clockwise or anticlockwise through 90°, depending on whether you want to increase or reduce the pressure. Finally, the plates should be secured in position.

The frame lifter (**illustration F**), which supports the door when it is closed, must be height-adjusted when the door is installed or after adjustment.

Loosen the two screws in the espagnolette – you will then see a small wheel at the bottom of the door frame. This wheel is adjusted up or down by loosening or tightening the two screws. The wheel must abut against the bottom casing when adjustment is complete.

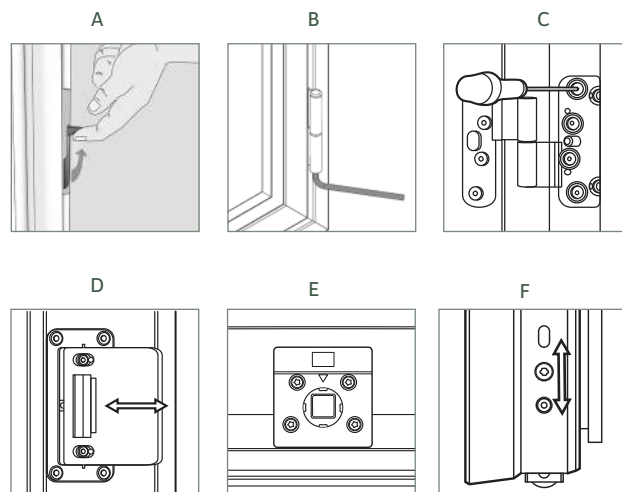
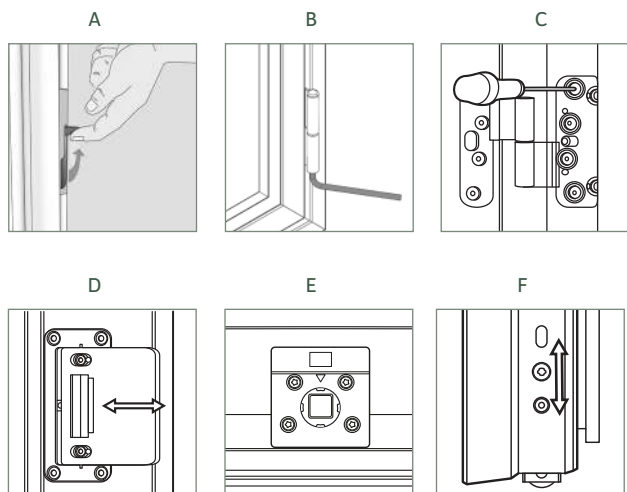



### Window door

Rationel AURA & AURAPLUS  
Rationel FORMA & FORMAPLUS

#### Operation

The Window door is operated using a handle which activates a closing mechanism with three locking points. This locking system comes equipped with a handle-operated brake that can hold the door in any open position up to 85 degrees. The handle-operated friction brake is operated by turning the handle to a vertical position when you have opened the door to the point where you want to hold it.

In very windy conditions, you must close the door or ensure that the door does not over extend and cause damage. The Window door is also available as a double door set. In this case, you open the slave leaf by activating the childproof lock on the handle.

#### Adjustment

If you need to adjust the height of the door leaf within the frame either when installing it or at a later date, this is done easily by loosening the screw on the centre hinge using a 5 mm Allen key (**illustration A**). Lateral adjustment is also possible using a 5 mm Allen key (**illustration B**). It is important to adjust the screws equally – the fittings must not be distorted. It is also possible to adjust the door leaf in the frame on the closing side by  $\pm 1$  mm by adjusting the frame lifter. A 4 mm Allen key is used for this (**illustration C**).

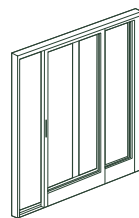

### Sliding patio door

Rationel AURA & AURAPLUS

#### Operation

Open the sliding door by rotating the handle downwards through 180°. This lifts the leaf so that it can be pushed to one side. The door can be secured in any position by rotating the handle back again. Ensure handle is fully down before operating/sliding door.

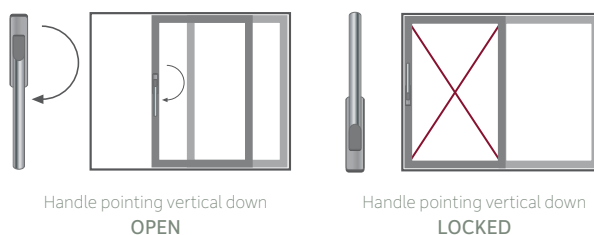

#### Adjustment

The closing pressure on the middle of the door can be adjusted by removing the small plastic plug (**illustration A**). The fitting is then adjusted using a torx 10 screwdriver.

Always keep the running track and wheel clear of dust to guarantee the best function.

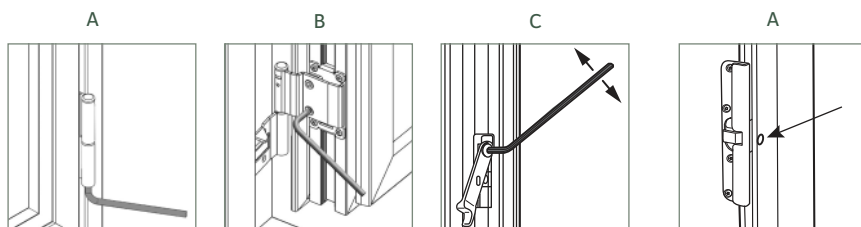

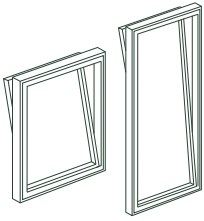

## Tilt and turn window and door

Rationel AURAPLUS

### Operation

The tilt and turn window and door is operated by the handle, which activates three functions:

#### 1) Bottom hung function:

When the handle is turned to the horizontal position, the frame tilts inwards from the top by approx. 10 cm. This allows for ventilation to enter the room.

#### 2) Side-hung function:

When the handle is turned to the vertical position, so that it points upwards, the frame can be opened inwards so that the external part of the element can be cleaned from inside. In very windy conditions, you must close the window or door, or ensure that the door does not over extend and cause damage.

#### 3) Closed element:

In the closed position, the handle must be in a vertical position.

Flawless operation of the bottom/side hung element is ensured by gently pressing the sash in towards the frame when switching between the three handle positions.

#### 4) Tilt & Turn restrictor:

The turn restrictor that prevents the sash from going into turn mode is mounted on the side of the hardware, between the sash and the frame. (**illustration A**, the restrictor sits on the handle side)

### Adjustment

If there is any need to adjust the element either when installing it or at a later date, the height can be adjusted by rotating the screw as shown in **illustration B**. The sash is adjusted laterally at the bottom by rotating the screw as shown in (**illustration C**). Use a 4 mm Allen key. The sash is adjusted laterally at the top by rotating the screw as shown in (**illustration D**). Use a 4 mm Allen key.

The sash pressure against the frame at the bottom can be adjusted by turning the nut on the underside of the frame using a 10 mm flat spanner (**illustration E**). The sash pressure against the frame at the top can be adjusted by turning the pawl on the frame using a 11 mm spanner (**illustration F**).

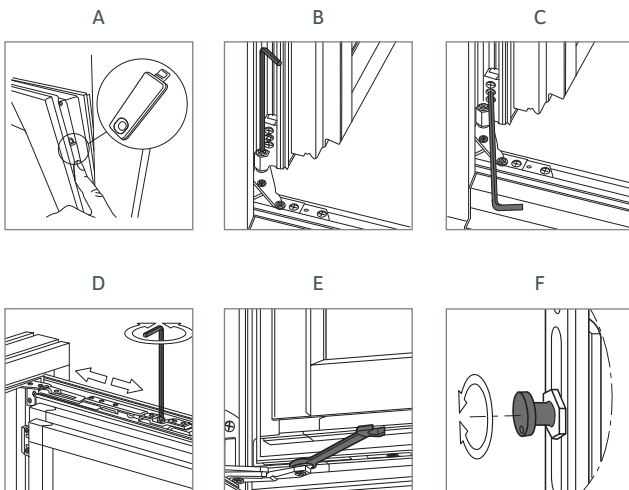

# Accessories



Top

## Standard window handle

The sash has 3 positions: closed, open and night vent position.



Top

## Window handle lockable

The lockable handle when in the closed position can be locked using a small removable key. When unlocked, the grey button must be pressed downwards while turning the handle to open and close the window.



Top

## Factory fitted restrictors

An optional built-in restrictor is available for security, preventing the window opening more than about 5 cm. To release the restrictor, pull the sash about 0,5 cm back, then press on the rear part of the restrictor and push the sash out.



Bottom

## Window handle with child restrictor

The handle with child restrictor is operated by pressing down on the grey button while turning the handle. The child restrictor will automatically re-engage when the sash is closed.



Bottom

## Trickle vents

The trickle vent provides background ventilation into a building when windows, doors etc. are closed. The vent is opened by pressing one or both of the push buttons at either end of the vent. To close the vent, push down on each end of the vent until it clicks shut.



Bottom

## Handle-operated brake

A handle-operated brake operates by allowing the window or door to be held in place at any desired position – however it is not suitable for use in strong winds. Only certain window and door opening styles can be fitted with handle-operated brakes.

# Record of Rationel products

Name

Adress of property



Date of purchase

Window / door location  
(bedroom, kitchen etc)

Rationel order number

Rationel item number

Window / door location (bedroom, kitchen etc)	Rationel order number	Rationel item number

## How to find order number

### Windows

To find the order and item number you need to look in the spacer bar, which is in the cavity between the panes of the glass. It is the only number that contains a slash and there will be either 6, 7 or 8 digits before the slash. If your doors and windows are delivered after January 2006, the order number consists of 7 digits before the slash and starts with 10-, 11-, 12-, 13-, 14- or 15. If your windows and doors are delivered after January 2019, the order number consists of 8 digits before the slash and starts with 2-, 3- or -4.



### Doors

On doors you will find the number on the label attached next to the door hinge.

# Glossary

## Windows and doors

The diagrams shown below will make it easier to understand the technical terms used in this manual.

### Windows

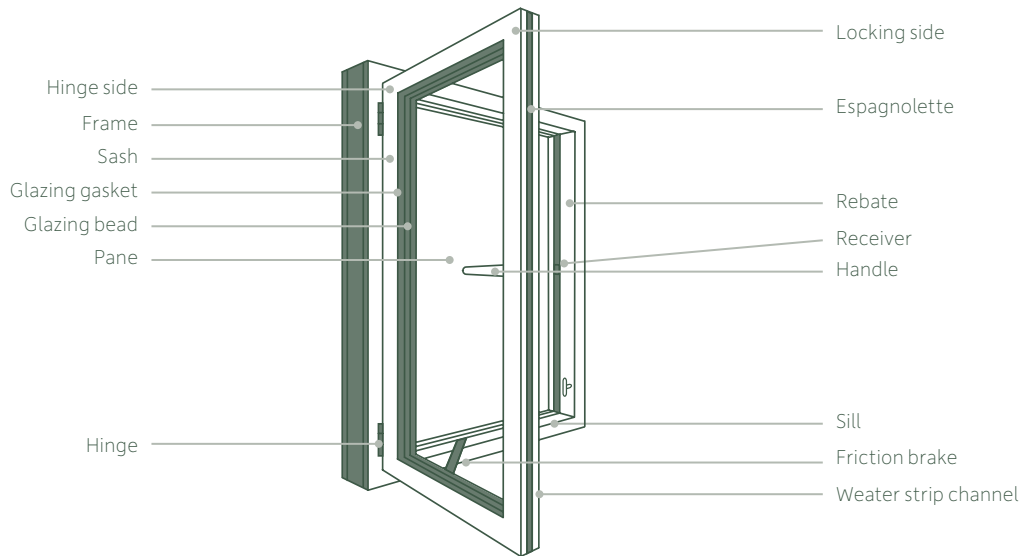

### Doors

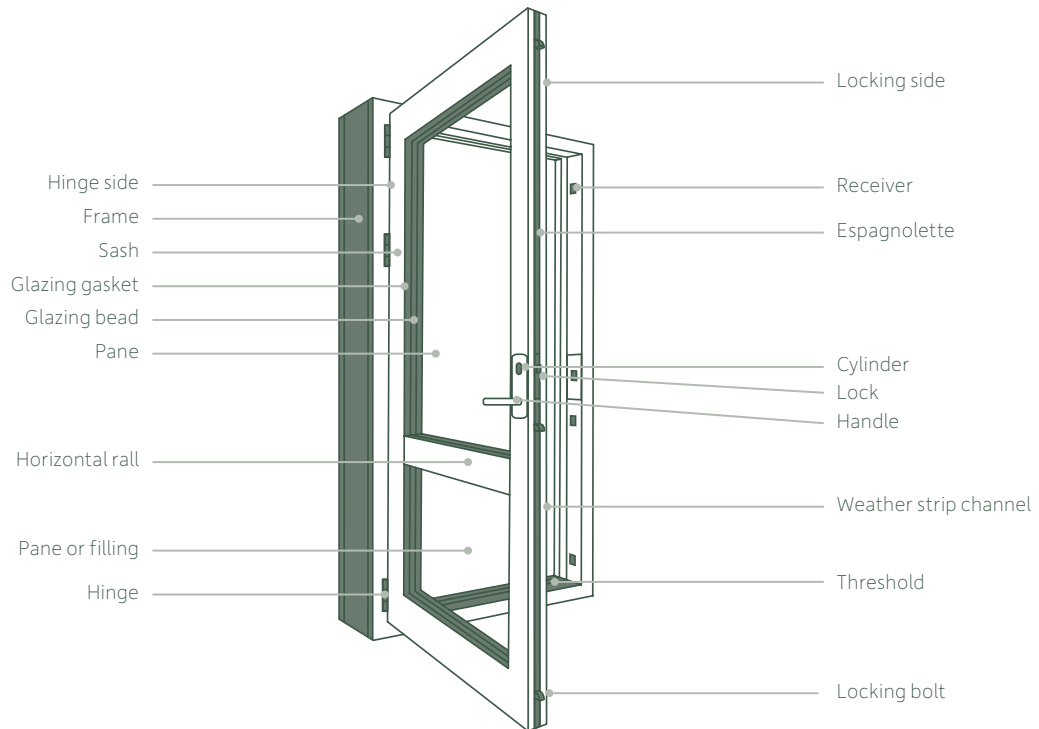



## Good, solid, quality craftsmanship

Rational first manufactured windows and doors in Sdr. Felding in 1954, and ever since the products have characterised quality and excellent workmanship. Based on this solid foundation, Rational has developed into an international company with sales activities in Denmark, Great Britain and Ireland.

As the market has developed, regulations and expectations changed, Rational has continuously sought to improve and expand its product range including efficient and energy saving products that exceed the statutory requirements of the future, whilst not compromising security, comfort or functionality.

Rational is part of the DOVISTA Group which consists of a number of leading door and window companies in Europe.

For further information about our wide range of windows and doors, please visit [www.rational.ie](http://www.rational.ie)